

September Homework- Week 4

Page 3-5: Cover Pages for Homework (English)- Choose from due date of Monday, Friday, or your choice.

- This page gives parents and students an overview of what they will be working on throughout the week. They will check a box as they complete each activity. When they are finished, both the parent and child will write their name on this cover page.

Pages 6-8: Math Homework (English)

Pages 9-12: Literacy Homework (English)

- Page 10 has 2 sets of leaves that students will cut out and glue onto page 9. Cut in half and staple to the back of page 9 when making the homework packet.

Page 13-15: Cover Pages for Homework (Spanish Directions)- Choose from due date of Monday, Friday, or your choice.

Pages 16-18: Math Homework (Spanish Directions)

Pages 19-22: Literacy Homework (Spanish Directions)

- Page 20 has 2 sets of leaves that students will cut out and glue onto page 19. Cut in half and staple to the back of page 19 when making the homework packet.

Preparing Homework Packet:

- Choose and print your Cover Pages (English and Spanish) and then print the homework pages.
 - Place the cover sheet on the top of the homework pages. This makes 1 homework packet.
 - Print as many English and Spanish packets as needed.
- Copy these pages to make a homework packet for each student in your class.
- Place the cover sheet on the top of each homework packet.
- Place the homework packet in your students homework folder or envelope.

****Make sure to download my FREE homework labels and how I put together these homework packets at my TPT store!*

Check out August-May monthly kindergarten homework at my TPT store:

<http://www.teacherspayteachers.com/Store/A-Spoonful-Of-Learning>

You can also grab an entire year of kindergarten homework bundled!

Check out my blog at: www.aspoonfuloflearning.blogspot.com



September Homework- Week 4

Math Common Core Standards:

- [K.CC.A.1](#) - Count to 100 by ones and by tens.
- [K.CC.A.3](#) - Write numbers from 0 to 20. Represent a number of objects with a written numeral 0-20 (with 0 representing a count of no objects).
- [K.CC.B.4.A](#) - When counting objects, say the number names in the standard order, pairing each object with one and only one number name and each number name with one and only one object.
- [K.CC.B.4.B](#) - Understand that the last number name said tells the number of objects counted. The number of objects is the same regardless of their arrangement or the order in which they were counted.
- [K.CC.B.5](#) - Count to answer "how many?" questions about as many as 20 things arranged in a line, a rectangular array, or a circle, or as many as 10 things in a scattered configuration; given a number from 1-20, count out that many objects.
- [K.G.A.2](#) - Correctly name shapes regardless of their orientations or overall size.
- [K.MD.B.3](#) - Classify objects into given categories; count the numbers of objects in each category and sort the categories by count.

Literacy Common Core Standards:

- [RF.K.1.A](#) - Follow words from left to right, top to bottom, and page by page.
- [RF.K.1.D](#) - Recognize and name all upper- and lowercase letters of the alphabet.
- [RF.K.3.A](#) - Demonstrate basic knowledge of one-to-one letter-sound correspondences by producing the primary sound or many of the most frequent sounds for each consonant.
- [RF.K.3.C](#) - Read common high-frequency words by sight (e.g., *the, of, to, you, she, my, is, are, do, does*).
- [RF.K.1.C](#) - Understand that words are separated by spaces in print.
- [L.K.2.D](#) - Spell simple words phonetically, drawing on knowledge of sound-letter relationships.

Dear Family,

Thank you for all of your help and support with your child's learning! This week your child has homework in math, reading, and writing!

Math Homework:

- Building Numbers:** Students will trace and write the number, draw to show the number, and fill in ten frames to show a number.
- Sorting 2D Shapes:** Students will sort different 2D shapes. (This is a cut and glue activity)
- Count and Write Numbers:** Students will count pictures and write the number to show how many pictures there are.

Reading & Writing Homework:

- Fall Tree Beginning Sounds:** Students will match pictures on a leaf to the tree that has the correct beginning sound letter as the picture.
- Drawing Beginning Sound Pictures:** Students will draw a picture that has the same beginning sound as the letter that is given.
- Let's Read and Write:** Students will read short sentences and find sight words in the sentences. Then, they will write their own sentence and draw a picture to go with it.

All of these activities are included with detailed directions on how to do each activity. Please return the completed homework on **Friday**. Thank you again!

Student Signature: _____

Parent or Guardian Signature: _____

Dear Family,

Thank you for all of your help and support with your child's learning! This week your child has homework in math, reading, and writing!

Math Homework:

- Building Numbers:** Students will trace and write the number, draw to show the number, and fill in ten frames to show a number.
- Sorting 2D Shapes:** Students will sort different 2D shapes. (This is a cut and glue activity)
- Count and Write Numbers:** Students will count pictures and write the number to show how many pictures there are.

Reading & Writing Homework:

- Fall Tree Beginning Sounds:** Students will match pictures on a leaf to the tree that has the correct beginning sound letter as the picture.
- Drawing Beginning Sound Pictures:** Students will draw a picture that has the same beginning sound as the letter that is given.
- Let's Read and Write:** Students will read short sentences and find sight words in the sentences. Then, they will write their own sentence and draw a picture to go with it.

All of these activities are included with detailed directions on how to do each activity. Please return the completed homework on **Monday**. Thank you again!

Student Signature: _____

Parent or Guardian Signature: _____

Dear Family,

Thank you for all of your help and support with your child's learning! This week your child has homework in math, reading, and writing!

Math Homework:

- Building Numbers:** Students will trace and write the number, draw to show the number, and fill in ten frames to show a number.
- Sorting 2D Shapes:** Students will sort different 2D shapes. (This is a cut and glue activity)
- Count and Write Numbers:** Students will count pictures and write the number to show how many pictures there are.

Reading & Writing Homework:

- Fall Tree Beginning Sounds:** Students will match pictures on a leaf to the tree that has the correct beginning sound letter as the picture.
- Drawing Beginning Sound Pictures:** Students will draw a picture that has the same beginning sound as the letter that is given.
- Let's Read and Write:** Students will read short sentences and find sight words in the sentences. Then, they will write their own sentence and draw a picture to go with it.



All of these activities are included with detailed directions on how to do each activity. Please return the completed homework on _____ . Thank you again!

Student Signature: _____

Parent or Guardian Signature: _____

Name: _____

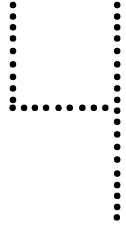
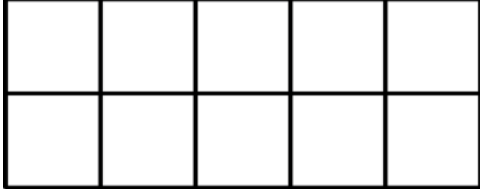
Building Numbers

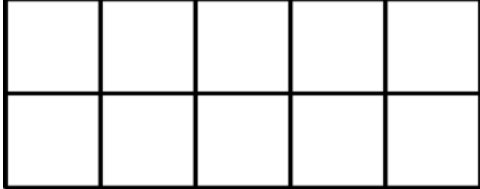
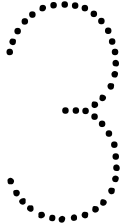
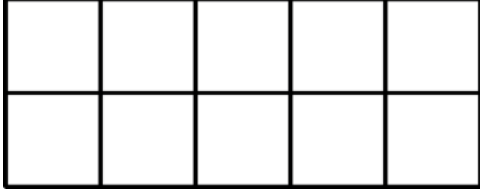
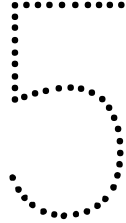
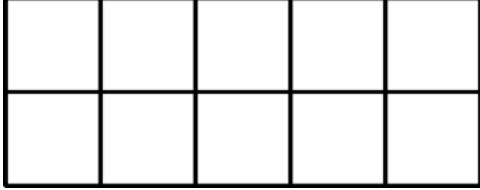
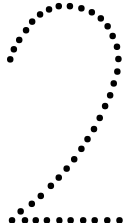
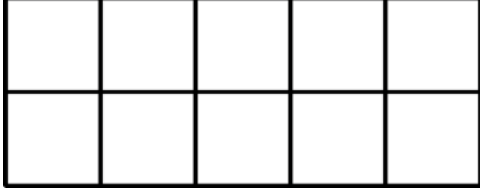
Trace	Write	Draw	Ten Frame
		Draw 4 circles	Make 4 dots in the ten frame 
		Draw 1 triangle	Make 1 dot in the ten frame 
		Draw 3 squares	Make 3 dots in the ten frame 
		Draw 5 rectangles	Make 5 dots in the ten frame 
		Draw 2 circles	Make 2 dots in the ten frame 

Name: _____

Sorting 2D Shapes

Cut out the shapes at the bottom of the page. Glue the shape in the correct box. Count how many you have of each shape and write the number on the line.

Circle

Triangle

Square

Rectangle

How many? _____

How many? _____

How many? _____

How many? _____

© A Spoonful of Learning

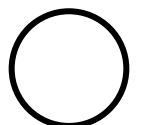
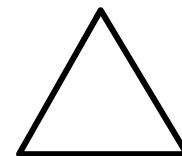
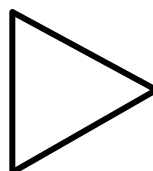
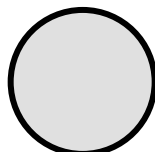
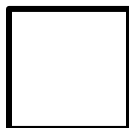
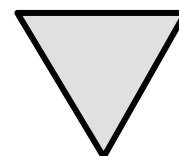
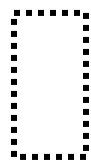
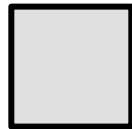
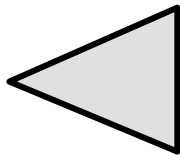
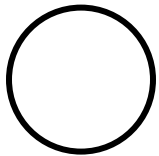

Name: _____

Counting and Writing Numbers!

Count the pencils and write the number in the box.

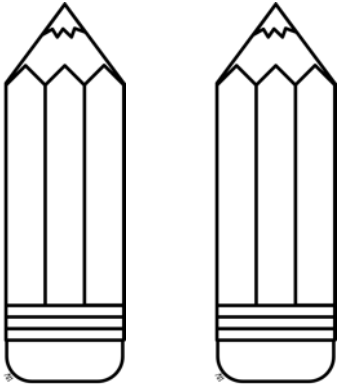

Two large pencils are shown side-by-side. To their right is a square box for writing the number.

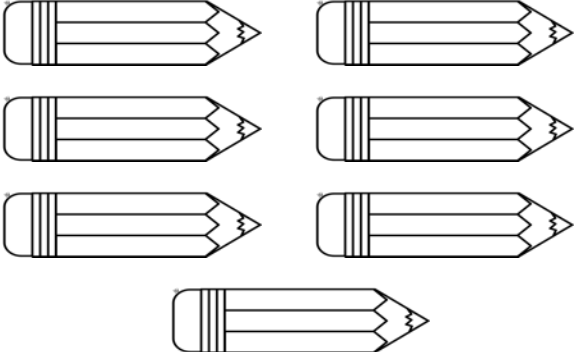

Seven small pencils are shown in two columns of three, with one pencil centered below them. To their right is a square box for writing the number.

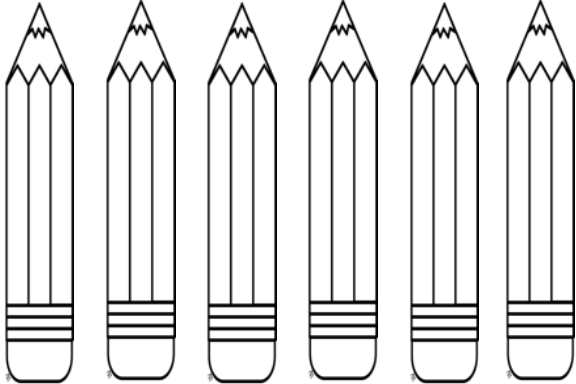

Six small pencils are shown in a single row. To their right is a square box for writing the number.

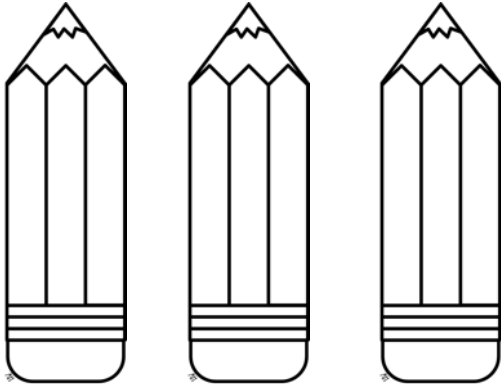

Three large pencils are shown side-by-side. To their right is a square box for writing the number.

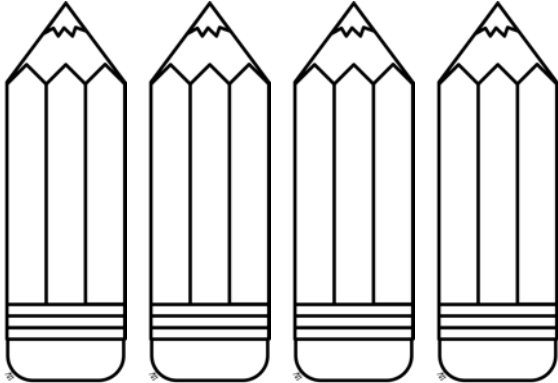

Four large pencils are shown side-by-side. To their right is a square box for writing the number.

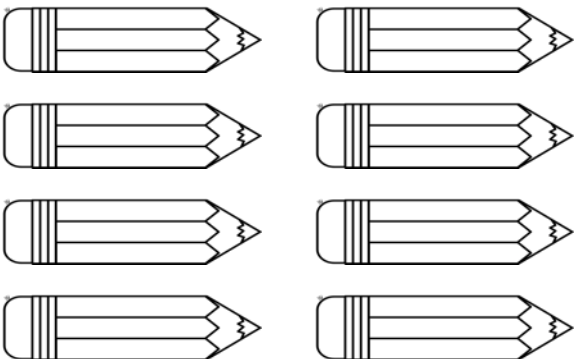



Ten small pencils are shown in two columns of five. To their right is a square box for writing the number.

Fall Trees Beginning Sounds!

Cut out the leaves that are attached. Say the picture name on the leaf and listen for the beginning sound. Glue the leaf on the box of the letter that the picture begins with.

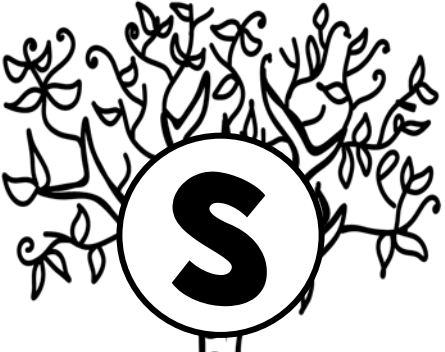
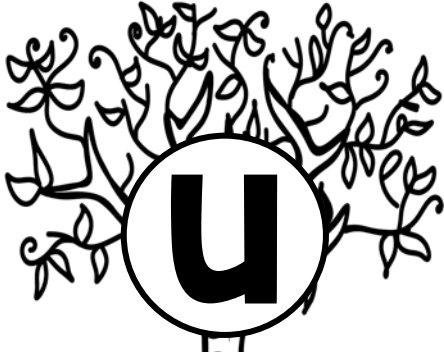
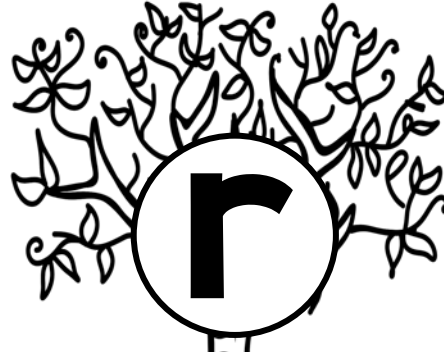
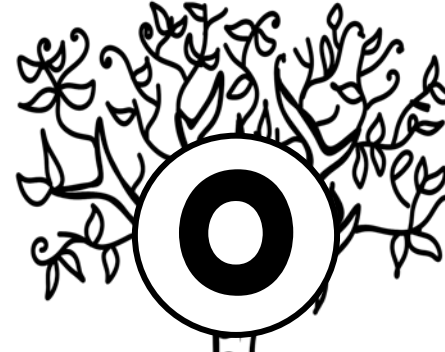
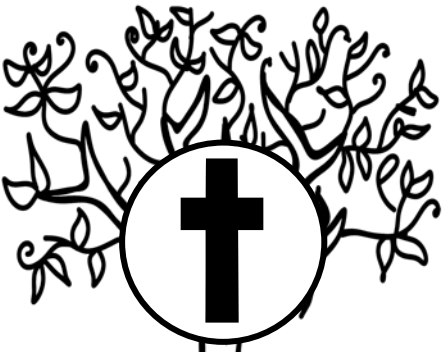
Name: _____

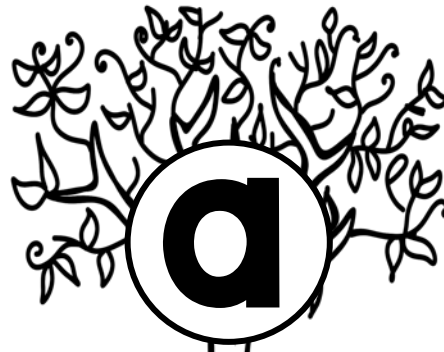
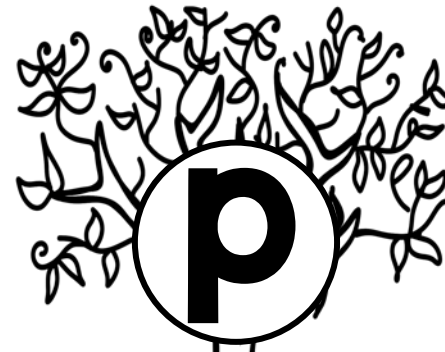
 <p>S</p> <input data-bbox="136 665 525 885" type="text"/>	 <p>U</p> <input data-bbox="609 665 997 885" type="text"/>	 <p>R</p> <input data-bbox="1081 665 1470 885" type="text"/>	 <p>O</p> <input data-bbox="1554 665 1942 885" type="text"/>
 <p>T</p> <input data-bbox="136 1282 525 1502" type="text"/>	 <p>M</p> <input data-bbox="609 1282 997 1502" type="text"/>	 <p>A</p> <input data-bbox="1081 1282 1470 1502" type="text"/>	 <p>P</p> <input data-bbox="1554 1282 1942 1502" type="text"/>

Cut out the leaves. Say the picture name on the leaf. Glue the leaf under the tree that has the correct beginning sound letter.

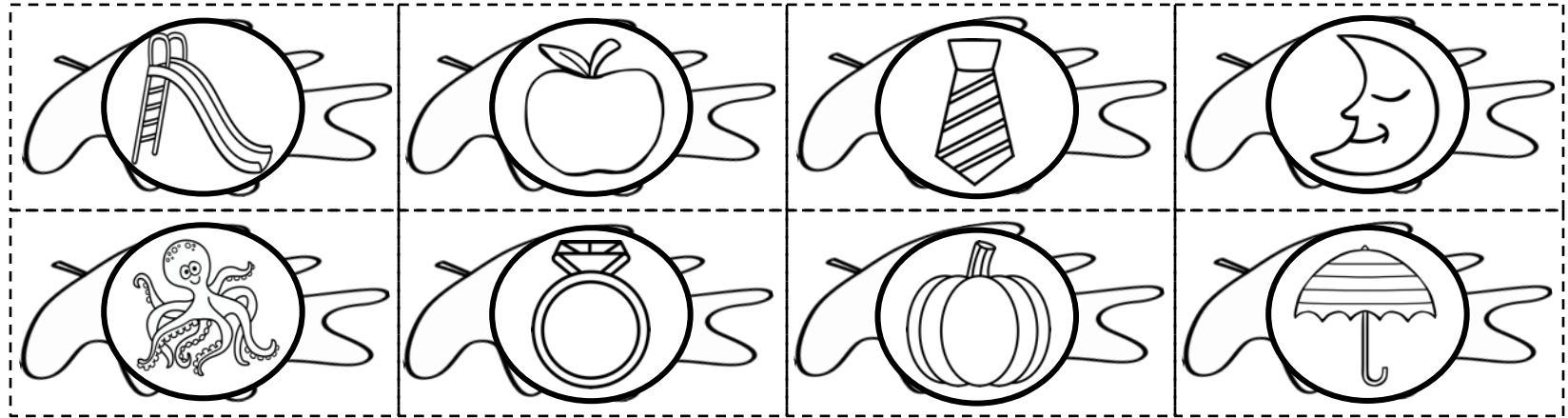

Cut out the leaves. Say the picture name on the leaf. Glue the leaf under the tree that has the correct beginning sound letter.

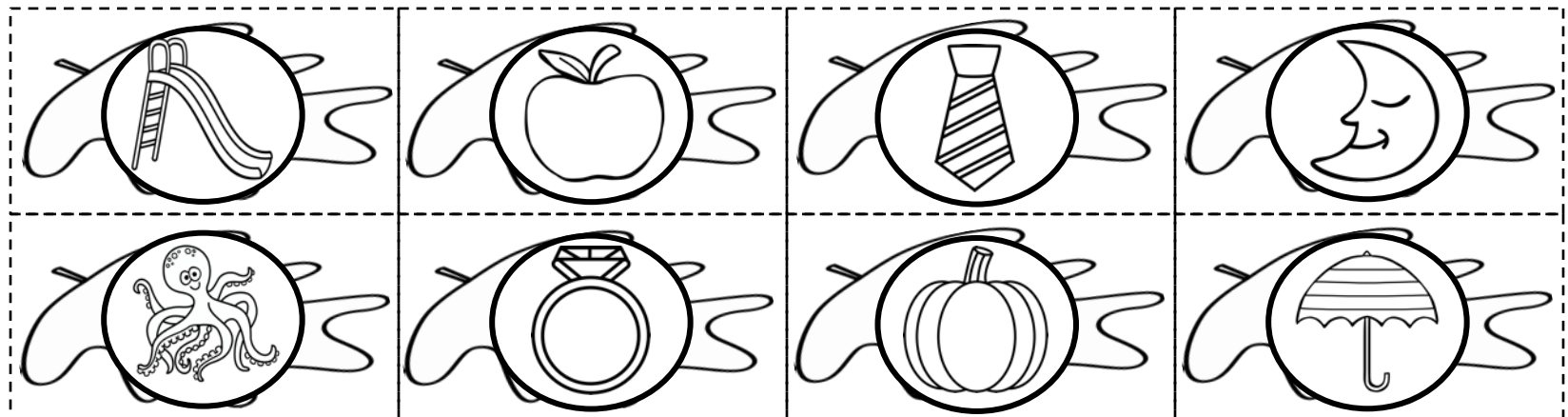

Drawing Beginning Sound Pictures

Name: _____

Trace the letter in each box. Draw a picture in the box that begins with that letter. (Ex: d, draw a dog)

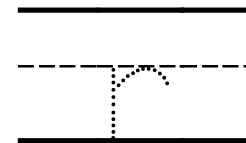
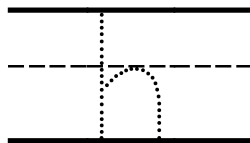
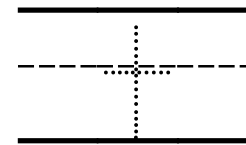
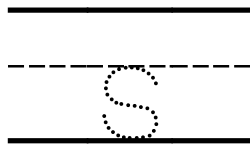

Let's Read and Write!

Name: _____

Read each sentence. Circle the sight word 'my'. Write a sentence about something that you see and draw a picture to go with it. Ex: I see my dog.

I can see my bus.

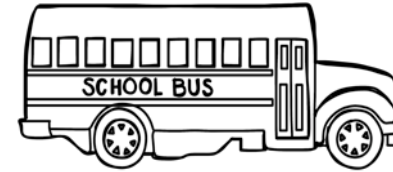

I can see my pencil.

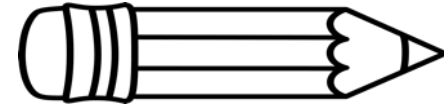

I can see my scissors.

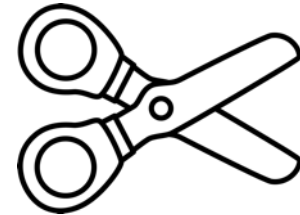

Write a sentence about what you can see.

Draw a picture to go with your sentence.

Estimada familia,

Gracias por toda su ayuda y apoyo en el aprendizaje de su hijo ! Esta semana su hijo tiene tarea en matemáticas, lectura, y la escritura!

Tarea de matemáticas:

- Números de construcción:** Los estudiantes trazar y escribir el número, dibujar para mostrar el número, y rellenar marcos de diez para mostrar un número.
- Ordenando de formas 2D:** Los estudiantes ordenaran diferentes formas 2D. (Esta es una actividad de corte y pegamento)
- contar y escribir los números:** Los estudiantes contarán fotos y escribir el número que indique la cantidad de imágenes que hay.

Lectura y Escritura de Tarea:

- árboles de la caída sonidos iniciales:** Que los estudiantes coincidan las imágenes en la hoja de árbol que tiene la carta de sonido principio correcto de la imagen.
- Dibujo imagenes con sonido inicial:** Que los estudiantes hagan un dibujo que tiene el mismo sonido inicial como la carta que se le da.
- Vamos a leer y escribir:** Los estudiantes leerán frases cortas y encontrar palabras de uso frecuente en las oraciones . Entonces , van a escribir su propia sentencia y hacer un dibujo para ir con ella.

Todas estas actividades se incluyen con instrucciones detalladas sobre cómo realizar cada actividad. Por favor devuelva la tarea terminada el **viernes**. Gracias de nuevo !

Firma del Estudiante: _____

Firma del Padre o Tutor: _____

Estimada familia,

Gracias por toda su ayuda y apoyo en el aprendizaje de su hijo ! Esta semana su hijo tiene tarea en matemáticas, lectura, y la escritura!

Tarea de matemáticas:

- Números de construcción:** Los estudiantes trazar y escribir el número, dibujar para mostrar el número, y rellenar marcos de diez para mostrar un número.
- Ordenando de formas 2D:** Los estudiantes ordenaran diferentes formas 2D. (Esta es una actividad de corte y pegamento)
- contar y escribir los números:** Los estudiantes contarán fotos y escribir el número que indique la cantidad de imágenes que hay.

Lectura y Escritura de Tarea:

- árboles de la caída sonidos iniciales:** Que los estudiantes coincidan las imágenes en la hoja de árbol que tiene la carta de sonido principio correcto de la imagen.
- Dibujo imagenes con sonido inicial:** Que los estudiantes hagan un dibujo que tiene el mismo sonido inicial como la carta que se le da.
- Vamos a leer y escribir:** Los estudiantes leerán frases cortas y encontrar palabras de uso frecuente en las oraciones . Entonces , van a escribir su propia sentencia y hacer un dibujo para ir con ella.

Todas estas actividades se incluyen con instrucciones detalladas sobre cómo realizar cada actividad. Por favor devuelva la tarea terminada el **lunes**. Gracias de nuevo !

Firma del Estudiante: _____

Firma del Padre o Tutor: _____

Estimada familia,

Gracias por toda su ayuda y apoyo en el aprendizaje de su hijo ! Esta semana su hijo tiene tarea en matemáticas, lectura, y la escritura!

Tarea de matemáticas:

- Números de construcción:** Los estudiantes trazar y escribir el número, dibujar para mostrar el número, y rellenar marcos de diez para mostrar un número.
- Ordenando de formas 2D:** Los estudiantes ordenaran diferentes formas 2D. (Esta es una actividad de corte y pegamento)
- contar y escribir los números:** Los estudiantes contarán fotos y escribir el número que indique la cantidad de imágenes que hay.

Lectura y Escritura de Tarea:

- árboles de la caída sonidos iniciales:** Que los estudiantes coincidan las imágenes en la hoja de árbol que tiene la carta de sonido principio correcto de la imagen.
- Dibujo imagenes con sonido inicial:** Que los estudiantes hagan un dibujo que tiene el mismo sonido inicial como la carta que se le da.
- Vamos a leer y escribir:** Los estudiantes leerán frases cortas y encontrar palabras de uso frecuente en las oraciones . Entonces , van a escribir su propia sentencia y hacer un dibujo para ir con ella.

Todas estas actividades se incluyen con instrucciones detalladas sobre cómo realizar cada actividad. Por



favor devuelva la tarea terminada _____ . Gracias de nuevo!

Firma del Estudiante: _____

Firma del Padre o Tutor: _____

Nombre: _____

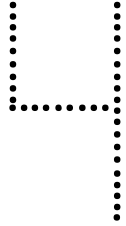
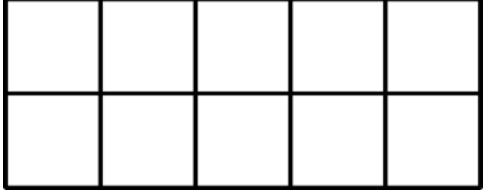
Números de construcción

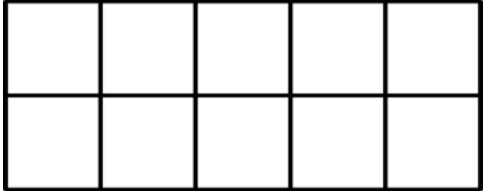
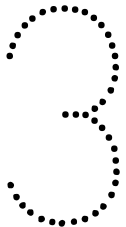
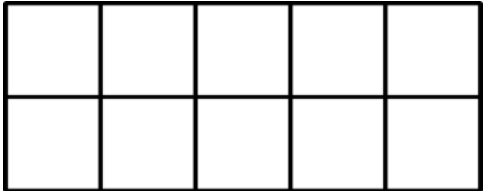
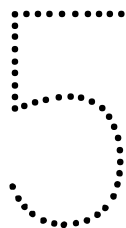
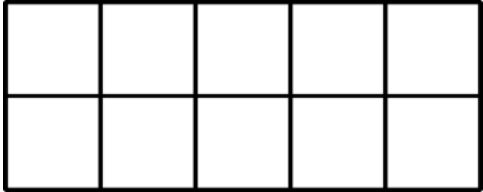
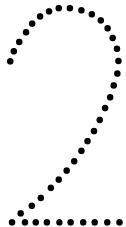
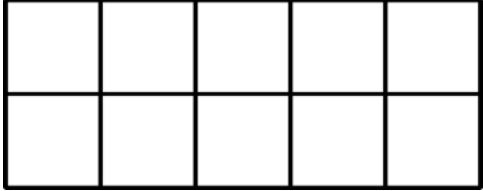
trazar	escribir	dibujar	diez de marco
		Draw 4 circles	Make 4 dots in the ten frame 
		Draw 1 triangle	Make 1 dot in the ten frame 
		Draw 3 squares	Make 3 dots in the ten frame 
		Draw 5 rectangles	Make 5 dots in the ten frame 
		Draw 2 circles	Make 2 dots in the ten frame 

Nombre: _____

Corte las formas en la parte inferior de la página.
Pegue la forma en la casilla correcta. Cuente cuántos
tiene de cada forma y escriba el número de la línea.

Ordenando formas 2D

Circulo

Triangulo

Cuadro

Rectangulo

¿Cuántos? _____

¿Cuántos? _____

¿Cuántos? _____

¿Cuántos? _____

© A Spoonful of Learning

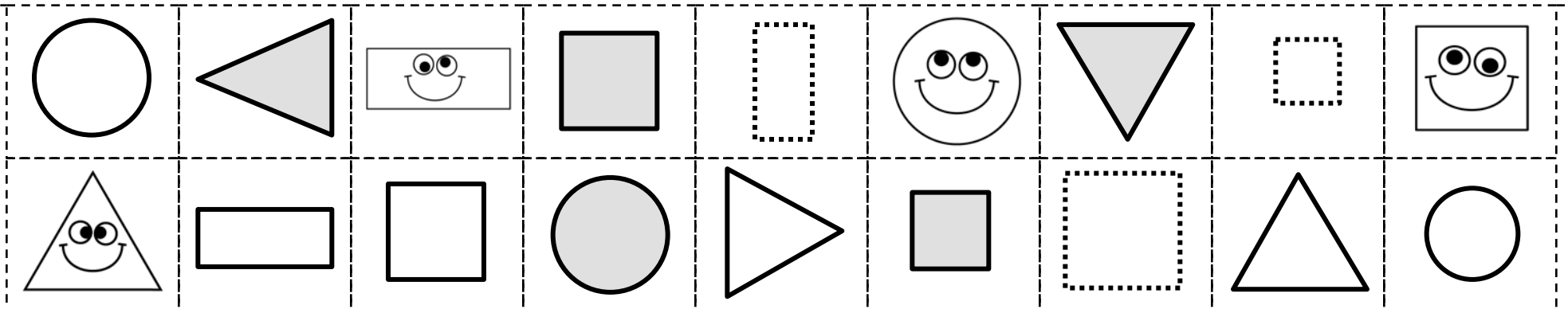

Nombre: _____

Contar y escribir numerous!

Cuente los lápices y escribir el número en el cuadro.

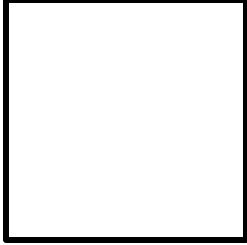
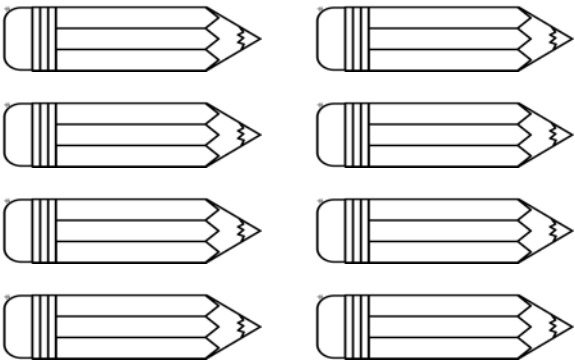
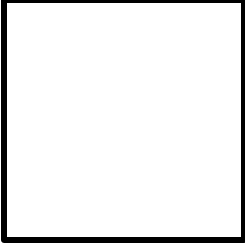
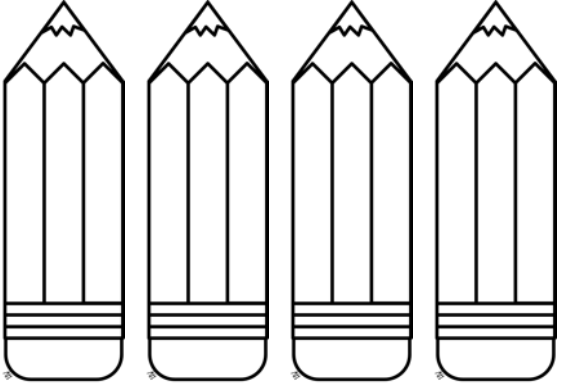
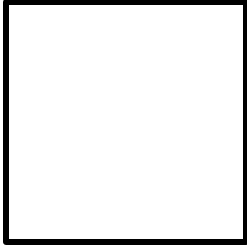
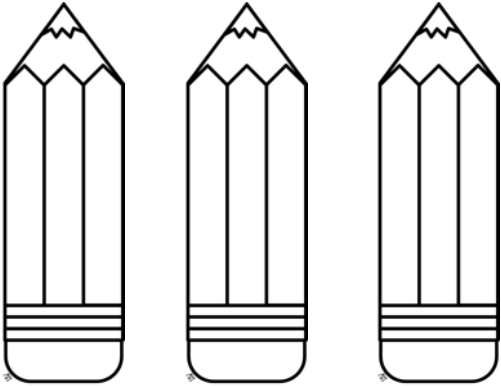
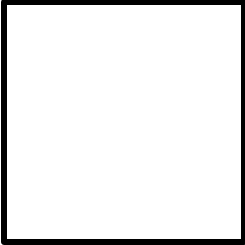
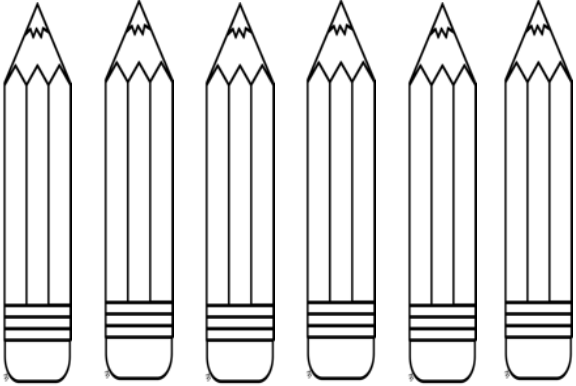
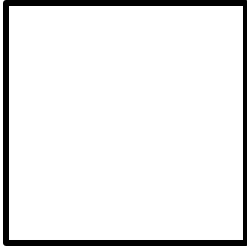
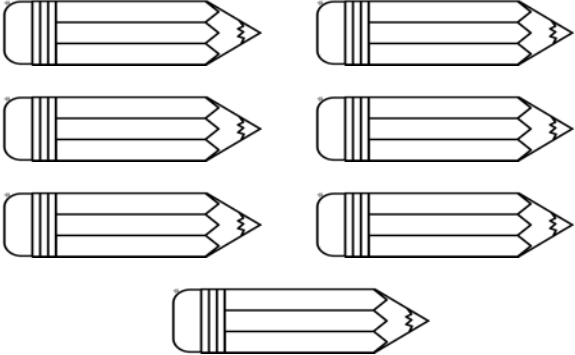
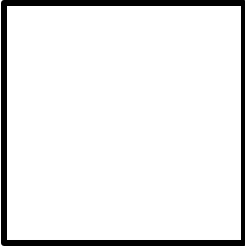
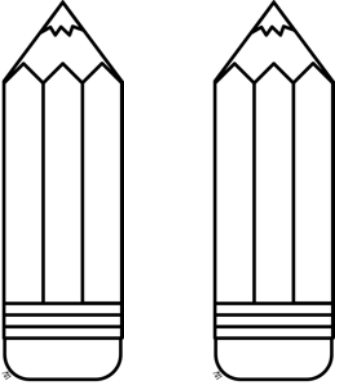

Árboles de la caída Sonidos iniciales!

Cortar las hojas que se adjuntan. Diga el nombre de la imagen en la hoja y escuche el sonido inicial. Pegue la hoja en el cuadro de la carta que la imagen comienza con.

Nombre: _____

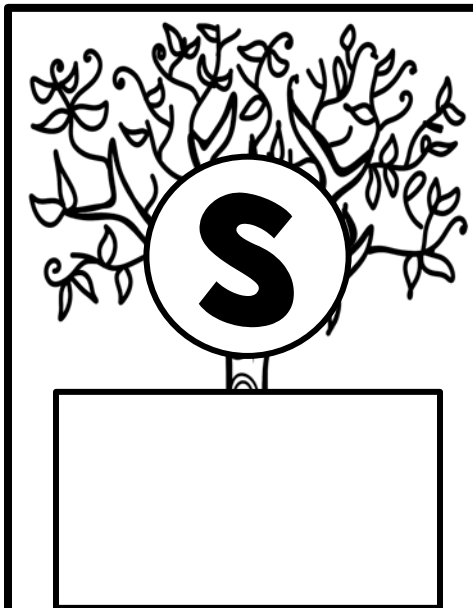

A tree with a large letter 'S' in a circle on its trunk. Below the tree is a rectangular box for labeling.

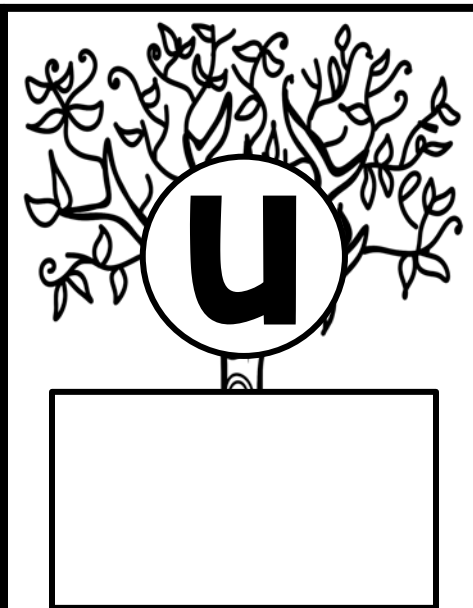

A tree with a large letter 'U' in a circle on its trunk. Below the tree is a rectangular box for labeling.

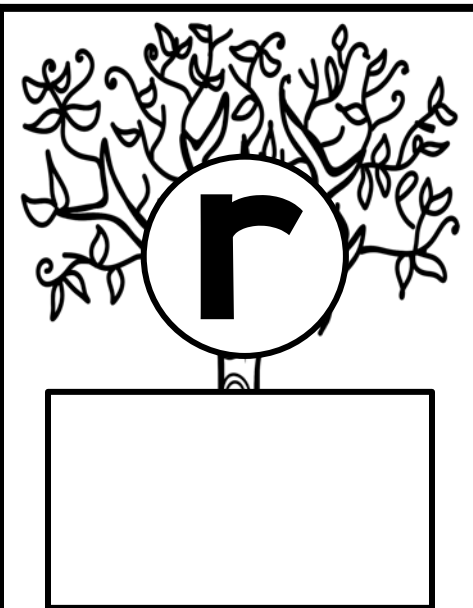

A tree with a large letter 'R' in a circle on its trunk. Below the tree is a rectangular box for labeling.

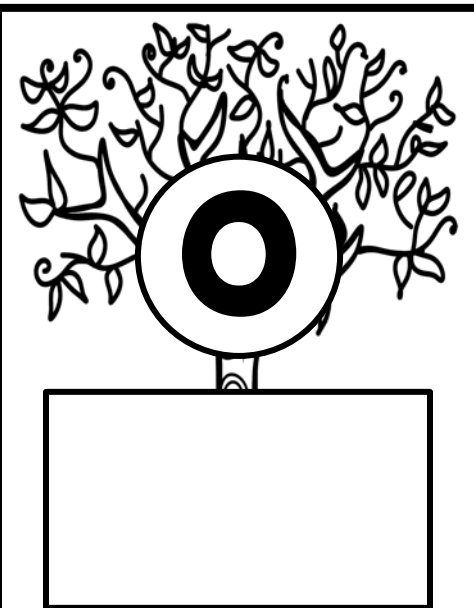

A tree with a large letter 'O' in a circle on its trunk. Below the tree is a rectangular box for labeling.

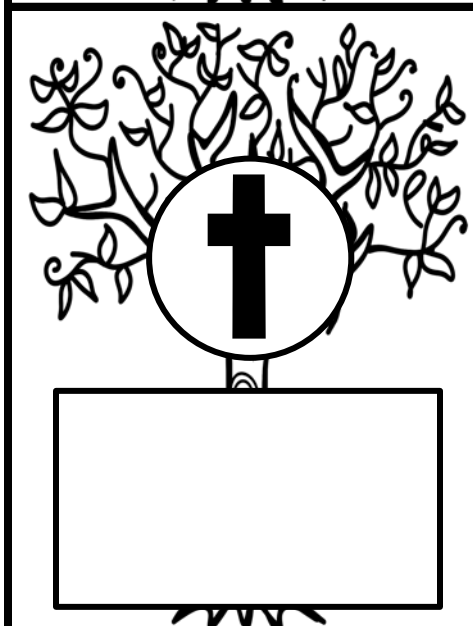

A tree with a large letter 'T' in a circle on its trunk. Below the tree is a rectangular box for labeling.

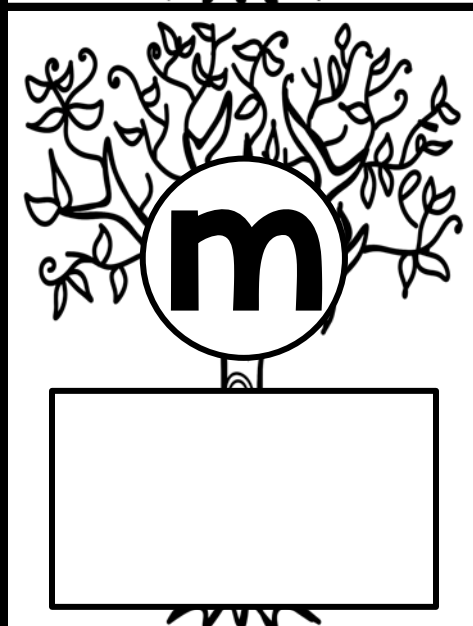

A tree with a large letter 'M' in a circle on its trunk. Below the tree is a rectangular box for labeling.

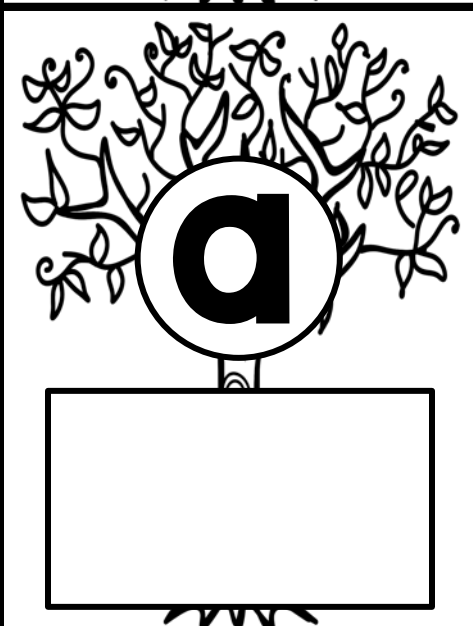

A tree with a large letter 'A' in a circle on its trunk. Below the tree is a rectangular box for labeling.

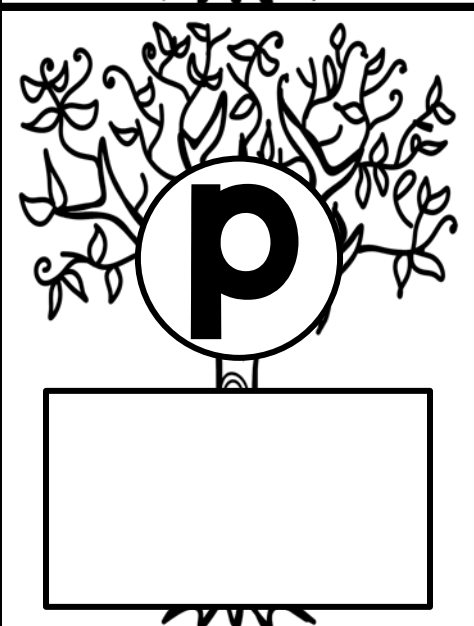

A tree with a large letter 'P' in a circle on its trunk. Below the tree is a rectangular box for labeling.

Cortar las hojas. Diga el nombre de la imagen en la hoja. Pegue la hoja bajo el árbol que tiene el sonido de la letra principio correcto.

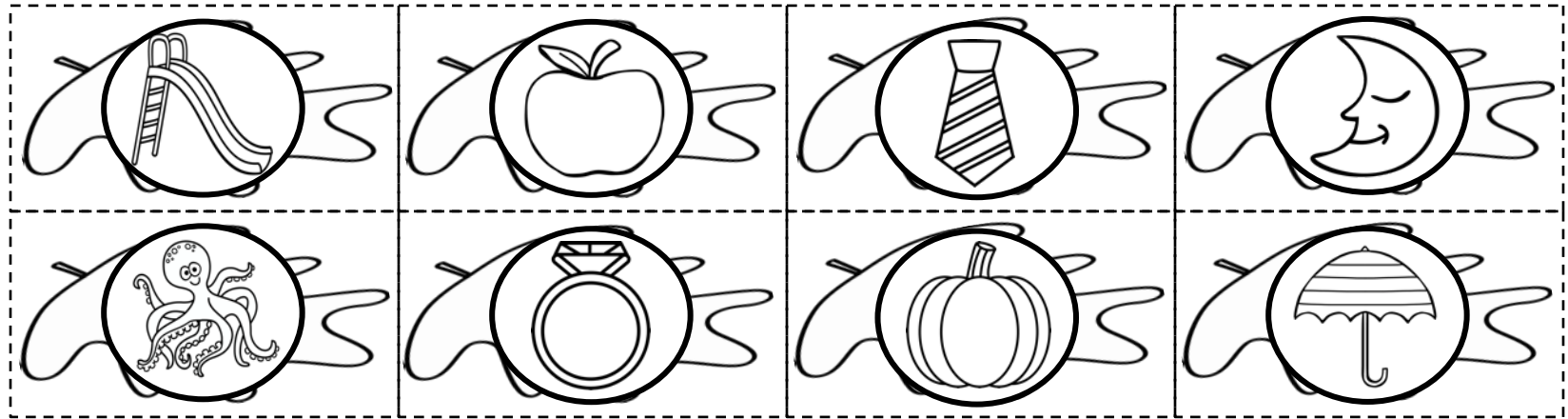

Cortar las hojas. Diga el nombre de la imagen en la hoja. Pegue la hoja bajo el árbol que tiene el sonido de la letra principio correcto.

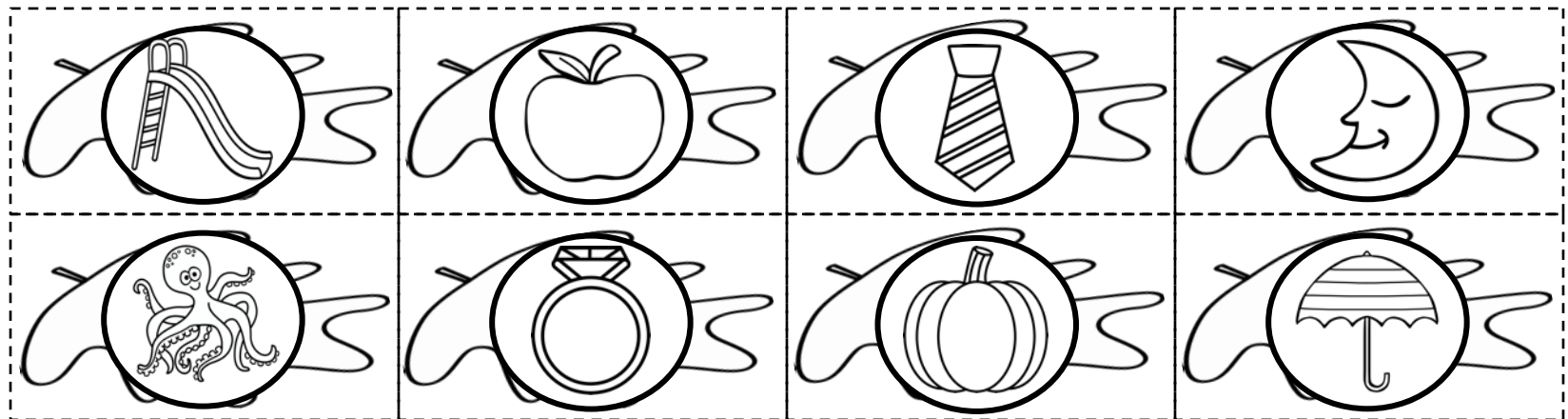

Dibujo imágenes con sonido inicial

Trazar la letra en cada casilla. Haz un dibujo en el cuadro que comienza con esa letra. (Ej: d, dibujar un perro)

Nombre: _____

s

t

h

r

Vamos a leer y escribir!

Lea cada frase. Círculo de la palabra de uso frecuente "mi".
Escribe una oración sobre algo que se ve y haz un dibujo
para ir con ella. Ejemplo: Veo a mi perro.

Nombre: _____

I can see my bus.

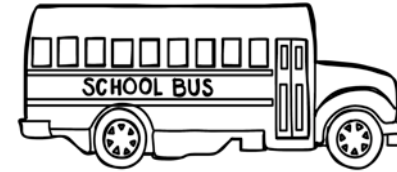

I can see my pencil.

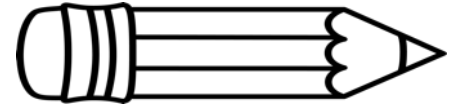

I can see my scissors.

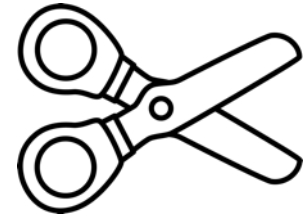

Escribe sobre lo que puede ver

Haz un dibujo para ir con su sentencia.